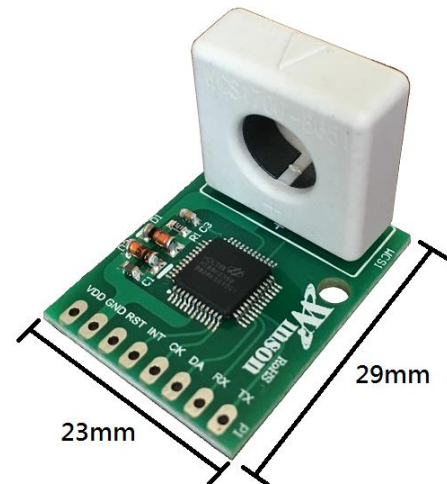

AC / DC Sensing Current Module with Digital Data output**Feature:**

- Operating voltage DC5.0V
- Diameter 9.0mm conductor through hole
- Sensing current range :
AC : 0~50A (50Hz, 60Hz)
DC : 0~±75A
- High accuracy :
AC : (0~15A) ± 0.15A
(15~50A) ± 1%
- DC : ±(0~15A) ± 0.3A
±(15~75A) ± 2%
- High resolution :
AC / DC : 54mA
- UART digital data output , Baud Rate : 9600 bps
- Temperature calibration
- Low power consumption mode
- Isolation Voltage 4KV

**General Description:**

The Winson WCM1600 provides economical and precise solution for both AC and DC current sensing in industrial, commercial and communications systems. The unique package allows for easy implementation without breaking original system and make current sensing possible. Typical applications include load detection and management, over-current fault detection and any intelligent power management system etc...

The WCM1600 consists of a current sensor, temperature sensor, a very high accuracy A/D converter and digital signal output of current.

The WCM1600 includes a current sensor with a diameter 9mm hole, users can just use system's own electric wire by pass it through this hole to measure passing current without breaking original system, user's MCU can get the real data from DATA pin.

The WCM1600 provides temperature calibration of the internal current sensor and accurately measures the current of AC 50 / 60Hz and DC at temperature from -20°C~70°C. The WCM1600 also offers solutions for true RMS current measurement of various loads.

Winson reserves the right to make changes to improve reliability or manufacturability.



1.VDD 2.GND 3.RST 4.INT 5.CK 6.DA 7.RX 8.TX

ABSOLUTE MAXIMUM RATING

Supply Voltage, Vdd	-----	6V
Pass Through Wire Diameter	-----	9mm
Basic Isolation Voltage	-----	4000V
Operating Temperature Range, Ta	-----	-20°C to +70°C
Storage Temperature Range, Ts	-----	-50°C to +125°C

Selection Guide:

Model	Maximum Current		Operating Voltage	mode
	AC	DC		
WCM1600-AC50C	50A	-	5.0V	Continuous
WCM1600-DC50C		±75A	5.0V	Continuous
WCM1600-50C	50A	±75A	5.0V	Continuous

Pad Description:

Pad No	Pad Name	I/O	Description
1	VDD	-	The positive power input pin
2	GND	-	The system ground
3	RST	I	The system reset
4	INT	I	Sampling control
5	CK	I/O	System programming, reserve
6	DA	I/O	
7	RX	I	The data of measured current output. Its output is UART communication. The baud rate is 9.6K bits/sec.
8	TX	O	

Winson reserves the right to make changes to improve reliability or manufacturability.

Electrical Characteristics:
-50C
TOP = 25°C, VDD = 5.000V

Symbol	Parameter	Test Condition	Min.	Typ.	Max.	Unit
VDD	Operation Voltage	-	4.9	5	5.1	V
IDD	Operation Current	-	-	6	8	mA
IOP	AC Current Range	-	0	-	50	A
	DC Current Range	-	0	-	±75	A
TOP	Operating Temperature	-	-20	-	70	°C
ETOT	AC Current Total Output Error	IOP=0~15A , TOP=25°C	-	±0.15	-	A
		IOP=15~50A , TOP=25°C	-	±1	-	%
		IOP=0~50A , TOP=-20°C to 70°C	-	±5	-	%
	DC Current Total Output Error	IOP=±(0~15) , TOP=25°C	-	±0.3	-	A
		IOP=±(15~75A) , TOP=25°C	-	±2	-	%
		IOP=0~±75A , TOP=-20°C to 70°C	-	±5	-	%

System Start Up Time Characteristics:

Symbol	Parameter	Test Condition	Min.	Typ.	Max.	Unit
TSST	System Start-up Time (Wake-up)	-	-	10	-	ms
TRSTD	System Reset Delay Time	-	-	1	-	s

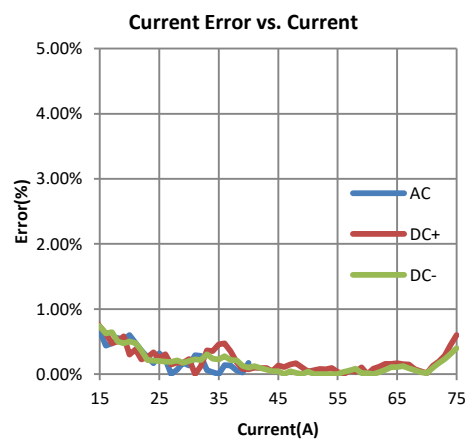
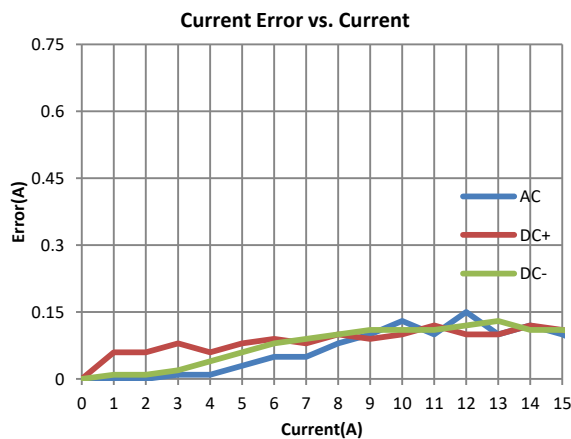

Winson reserves the right to make changes to improve reliability or manufacturability.

Application Note:

Application Diagram:

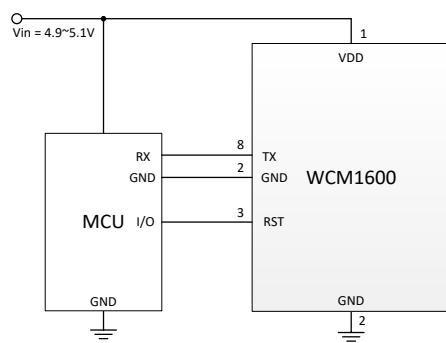

APP. 1. Output UART signal with MCU

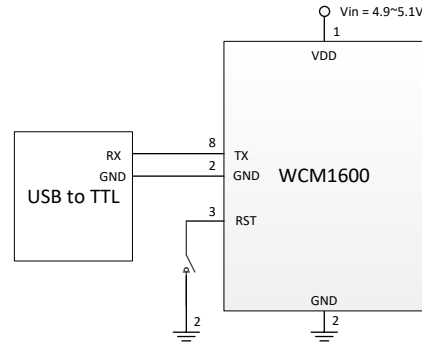

APP. 2. Output UART signal with USB to TTL

Measured Current Data Output:

The measured current can be transmitted by UART format.

- (1) If the measured data is AC "1.23"A, then the output data is '~', '0', '1', '2', '3', '0', '\r', '\n', total of 8 bytes; the output data is ASCII code. If the measured data is "10.76" A, then the output data is '~', '1', '0', '7', '6', '0', '\r', '\n', total of 8 bytes.
- (2) If the measured data is +DC "1.23"A, then the output data is '+', '0', '1', '2', '3', '0', '\r', '\n', total of 8 bytes; the output data is ASCII code. If the measured data is "10.76" A, then the output data is '+', '1', '0', '7', '6', '0', '\r', '\n', total of 8 bytes.
- (3) If the measured data is -DC "1.23"A, then the output data is '-', '0', '1', '2', '3', '0', '\r', '\n', total of 8 bytes; the output data is ASCII code. If the measured data is "10.76" A, then the output data is '-', '1', '0', '7', '6', '0', '\r', '\n', total of 8 bytes.

Winson reserves the right to make changes to improve reliability or manufacturability.

True RMS Current Measurement:

In order to calculate true RMS of AC current, you need to know “zero” value of AC current first. The “zero” value of symmetric AC current is the average value $V_o(dc)$ of the current shown in Figure 1.

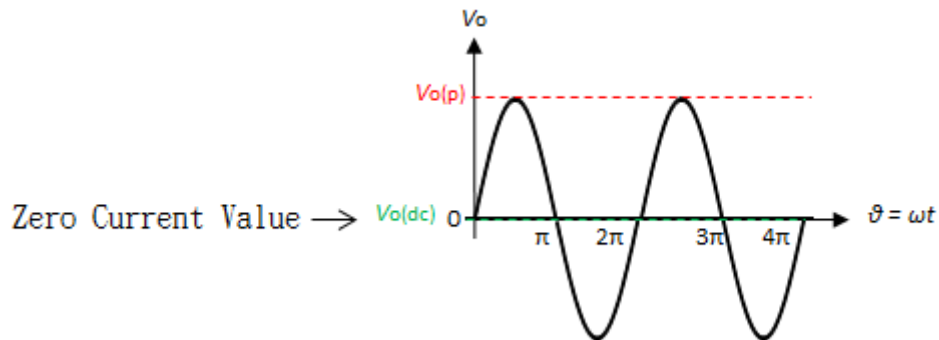

Figure 1 The zero current value of sine waveform

But in asymmetrical AC current, the “zero” value is not the average value $V_o(dc)$ of the current. Based on this “zero” value and do RMS calculation. You will get wrong answer.

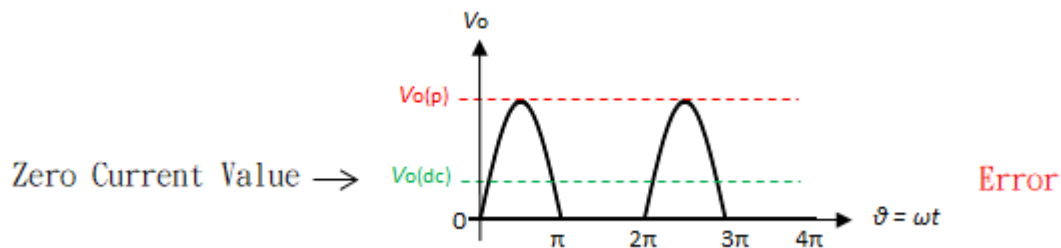

Figure 2 The zero current value of the asymmetric waveform (Error)

The WCM1600 offers a true RMS solution for both symmetric and asymmetric AC current. It can correctly detect “zero” current value, shown in Figure 3. and do perfect RMS calculation.

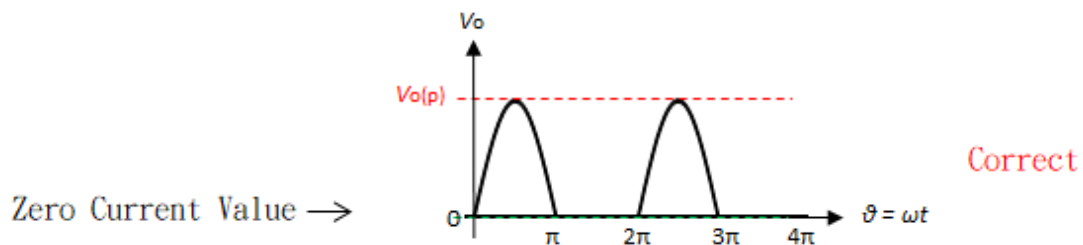
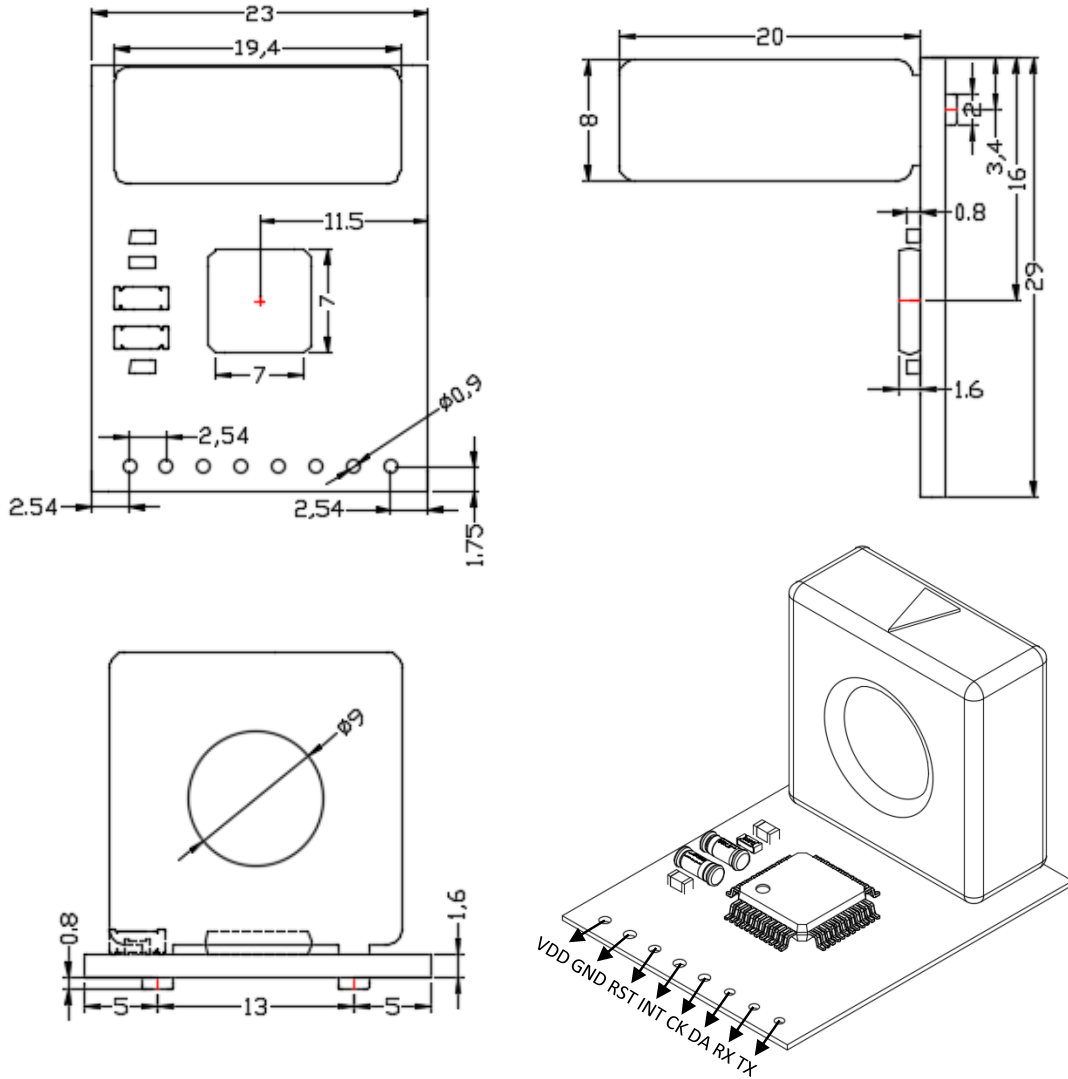

Figure 3 The zero current value of the asymmetric waveform (Correct)

Package:

(Unit: mm)



WCM Application Note : please refer to Winson Website -> Products-> Application Note -> WCM Application Note :

<http://www.winson.com.tw/Product/83>

Winson reserves the right to make changes to improve reliability or manufacturability.