

REV	DATE	ECN NO.	MODIFICATION	APPROVER
A	2016/10/14		NEW	Jason_Lee
A1	2017/05/15	RD00317051501	SIZE CHANGE	Jason_Lee

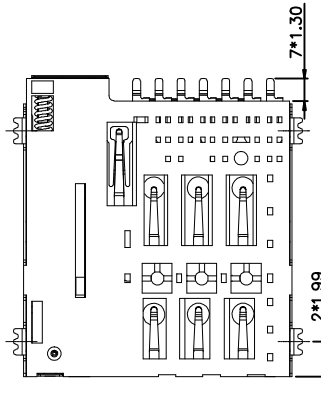

NOTES:
MATERIAL:
Housing: High Temperature thermoplastic, UL94V-0
Terminal: Copper Alloy
Shell: Stainless
SPECIALTY:
Rated Current: 0.5A MAX
Rated Voltage: 50V
Ambient Temperature Range: -20°C~+60°C
Storage Temperature Range: -40°C~+70°C
Ambient Humidity Range: 95% R.H. Max.
Contact Resistance: 100mΩ Max
Insulation Resistance: 1000MΩ/250V DC
Dielectric Withstanding Voltage: 500V AC
Durability: 5000 cycles
Temperature 260±5°C

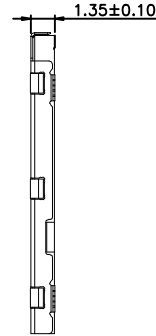
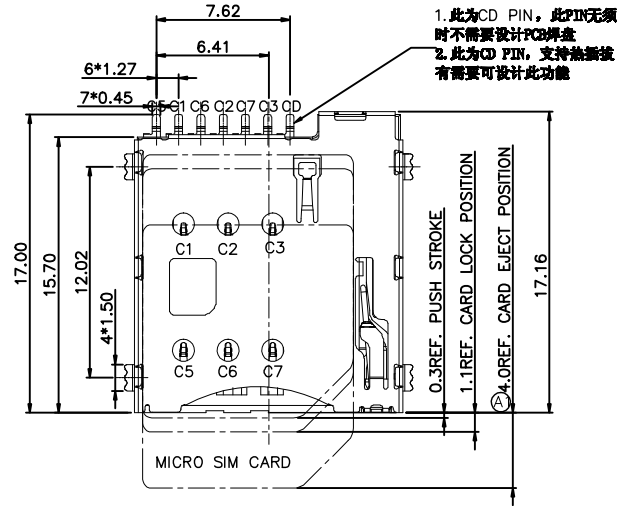
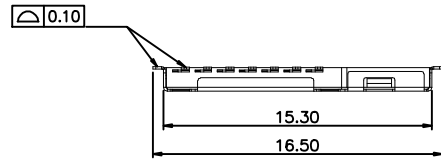
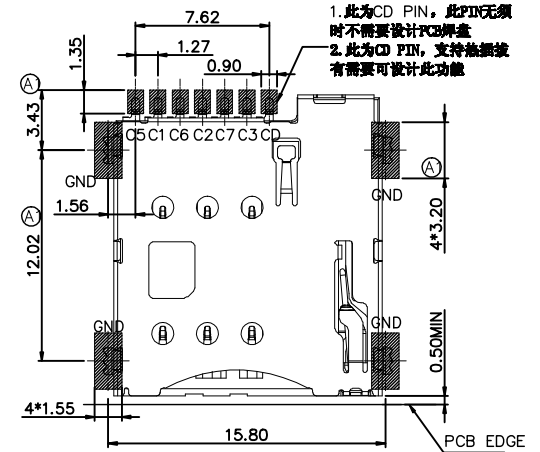

IN#	Name
C1	VCC
C2	RST
C3	CLK
C5	GND
C6	VPP
C7	I/O

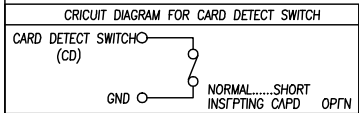
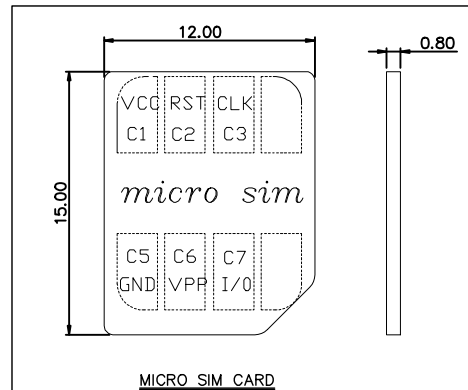
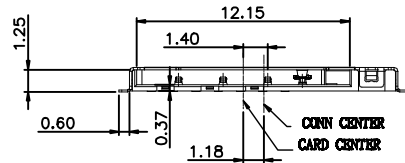

GENERAL TOLERANCE			UNITS	NAME:	ATOM [®] 深圳市爱特姆科技有限公司 SHENZHEN ATOM TECHNOLOGY CO., LTD.	
SELECT	TOL	1 2 3	mm	NAME: MICRO SIM CARD 6P PUSH PUSH	PART NO:	TITLE: MICRO SIM CARD 6P PUSH PUSH SMT H=1.35mm 带检测脚 无柱
ON.					SI62C-01200	DWG NO. ATOM-A03337
X.XXX	±0.10±0.05±0.15		MAT'L	APPD:		SCALE SHEET REV
X.XX	±0.15±0.13±0.25		FINISH	CHKD:		1:1 1/1 A1
X.X	±0.20±0.25±0.5		Q'TY	DR:	JACK	
X.	±0.30±0.38±1.00					
ANGLE	±2'					